

Trigonal Planar Phosphorus Cations

OLIVIER GUERRET AND GUY BERTRAND*

Laboratoire de Chimie de Coordination,
205, route de Narbonne, 31077 Toulouse, Cédex-4, France

Received April 9, 1997

Amino substituents are very effective stabilizing groups for electron-deficient species. Indeed, several diaminocarbenes **A**¹ and aminonitrenes (1,1-diazenes) **B**² have been isolated. Phosphino groups have also been used with the same aim, but so far, only a few stable phosphinocarbenes **A'** are known³ while phosphinonitrenes **B'** are still considered as transient species.⁴ The apparent greater stabilizing effect of nitrogen compared to phosphorus is even more striking when cationic moieties are considered. Amino-substituted carbocations, namely iminium salts **C** have been widely used in organic synthesis, while the chemistry of phosphinocarbenium (methylenephosphonium salts) **C'** is still in its infancy. Similarly, an aminonitrenium **D** has been recently isolated,⁵ but so far, no stable phosphinonitrenium (iminophosphonium salts) **D'** are known. Interestingly, according to Schleyer et al.,⁶ "the inherent π donor capabilities of the heavier elements are as large as or larger than their second-row counterparts". However, the same authors stated that "the apparently superior ability of nitrogen to act as a π donor is due, in part, to the ease in achieving the optimum planar configurations with sp^2 hybridization".

This review deals with the synthesis, characterization, and bonding description of trigonal planar phosphorus cations. First, the chemistry of methylenephosphonium and iminophosphonium salts **C'** and **D'**, which are iso-electronic and isovalent to alkenes and imines, respectively, will be presented. Then, the possible existence of oxo-, thioxo-, and selenoxophosphonium ions **E'**, which are related to the well-known acylium cations **E** will be discussed. Numerous phosphonium complexes of type **F**, in which a phosphonium ion is used to form a coordination bond with a 16-electron transition metal fragment, are known⁷ but are not included in this review (Figure 1).

A. Methylenephosphonium Ions. (a) Synthesis. The complexity of the bonding situation in methylenephosphonium ions **C'** is reflected by a retrosynthetic analysis: five different routes can be proposed (Figure 2).

Olivier Guerret was born in Montpellier in 1971. He graduated in 1994 from Ecole Polytechnique at Palaiseau and is currently preparing his Ph.D. under the supervision of Professor G. Bertrand.

Guy Bertrand was born in Limoges in 1952. He graduated (ingénieur ENSCM) from the University of Montpellier and moved to the University Paul Sabatier as an "Attaché de Recherche CNRS" in 1975. Since 1988, he has been "Directeur de Recherche" at the Laboratoire de Chimie de Coordination du CNRS at Toulouse. His research spans a wide range of topics at the border between organic and inorganic chemistry. He serves as an Editorial Board member of *Heteroatom Chem.*, *Bull. Soc. Chim. Fr.*, *Top. Stereochem.*, and *Chem. Rev.* He has received the International Council on Main Group Chemistry Award in 1993 and the Humboldt Award in 1994 and has been elected Membre Correspondant of the French Academy of Sciences in 1996.

Since the methylenephosphonium ion **C'** can be described as a carbocation stabilized by a phosphino substituent, the most obvious route to their synthesis should be via the heterolytic cleavage of a C–X bond in the position α to phosphorus (route a): interestingly this approach is the only one which has never been reported! We should realize that the formation of methylenephosphonium salts by this route implies the planarization of the heteroatom which is, as mentioned above, energetically less favorable for phosphorus than for nitrogen (inversion barrier: PH_3 , 37.3 kcal·mol⁻¹; NH_3 , 5.8 kcal·mol⁻¹).⁸

By analogy with the synthesis of iminium salts, addition of electrophiles to phosphalkenes could be envisaged (route b). However, the comparison of phosphalkenes with imines is misleading because very often the polarity of the heteroatom–carbon double bond is reversed ($\text{N}^{\delta-}\text{C}^{\delta+}$ and $\text{C}^{\delta-}\text{P}^{\delta+}$) and the HOMO is not the phosphorus lone pair but the π -bond.⁹ A good illustration is given by comparing the reactivity of pyridine with that of phosphinine (eq 1). Pyridinium salts are easily available by electrophilic addition, whereas protonation of phosphinines occurs at the α -carbon and not at the phosphorus atom.¹⁰

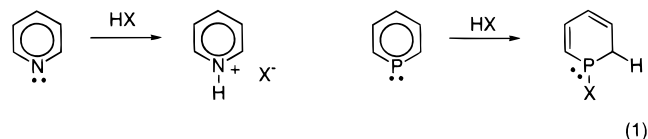

In 1989, we prepared the first stable methylenephosphonium salt **2a** according to route c.¹¹ The starting material is the phosphinocarbene **1a** which is best described as a phosphorus vinyl ylide and already features

- (1) Arduengo, A. J., III; Harlow, R. L.; Kline, M. *J. Am. Chem. Soc.* **1991**, *113*, 361. Arduengo, A. J., III; Dias, H. V. R.; Harlow, R. L.; Kline, M. *J. Am. Chem. Soc.* **1992**, *114*, 5530. Khun, N.; Kratz, T. *Synthesis* **1993**, 1993, 561. Arduengo, A. J., III; Goerlich, J. R.; Marshall, W. J. *J. Am. Chem. Soc.* **1995**, *117*, 11027. Enders, D.; Breuer, K.; Raabe, G.; Runsink, J.; Teles, J. H.; Melder, J. P.; Ebel, K.; Brode, J. *Angew. Chem., Int. Ed. Engl.* **1995**, *34*, 9, 1021. Alder, R. W.; Allen, P. R.; Murray, M.; Orpen, A. G. *Angew. Chem., Int. Ed. Engl.* **1996**, *35*, 1121.
- (2) Sylwester, A. P.; Dervan, P. B. *J. Am. Chem. Soc.* **1984**, *106*, 4648 and references therein.
- (3) Igau, A.; Grützmacher, H.; Baceiredo, A.; Bertrand, G. *J. Am. Chem. Soc.* **1988**, *110*, 6463. Igau, A.; Baceiredo, A.; Trinquier, G.; Bertrand, G. *Angew. Chem., Int. Ed. Engl.* **1989**, *28*, 621. Gillette, G.; Baceiredo, A.; Bertrand, G. *Ibid.* **1990**, *29*, 1123. Gillette, G.; Igau, A.; Baceiredo, A.; Bertrand, G. *New J. Chem.* **1991**, *15*, 393.
- (4) Bertrand, G.; Majoral, J. P.; Baceiredo, A. *Acc. Chem. Res.* **1986**, *19*, 17. Granier, M.; Baceiredo, A.; Dartiguenave, Y.; Menu, M. J.; Bertrand, G. *J. Am. Chem. Soc.* **1990**, *112*, 6277.
- (5) Boche, G.; Andrews, P.; Harms, K.; Marsh, M.; Rangappa, K. S.; Schimeczek, M.; Willeke, C. *J. Am. Chem. Soc.* **1996**, *118*, 4925.
- (6) Kapp, J.; Schade, C.; M. El-Nahasa, A.; Schleyer, P. v. R. *Angew. Chem., Int. Ed. Engl.* **1996**, *35*, 2236. See also: Bernardi, F.; Bottoni, A.; Venturini, A. *J. Am. Chem. Soc.* **1986**, *108*, 6395. Schade, C.; Schleyer, P. v. R. *J. Chem. Soc., Chem. Commun.* **1987**, 1399. Lohr, L. L.; Schlegel, H. B.; Morokuma, K. *J. Phys. Chem.* **1984**, *88*, 1981.
- (7) See, for example: Cowley, A. H.; Kemp, R. A. *Chem. Rev.* **1985**, *85*, 367. Nakazawa, H.; Yamaguchi, Y.; Mizuta, T.; Ichimura, S.; Miyoshi, K. *Organometallics* **1995**, *14*, 4635. Gudat, D.; Schrott, M.; Nieger, M. *J. Chem. Soc. Chem. Commun.* **1995**, 1541.
- (8) Snaken, J. D.; Ibers, J. A. *J. Chem. Phys.* **1962**, *36*, 1914. Woston, R. E., Jr. *J. Am. Chem. Soc.* **1954**, *76*, 2645.
- (9) Schoeller, W. W. In *Multiple Bonds and Low Coordination in Phosphorus Chemistry*; Regitz, M., Scherer, O. J., Eds.; Thieme: Stuttgart, Germany, 1990; p 5.
- (10) Märkl, G. In *Multiple Bonds and Low Coordination in Phosphorus Chemistry*; Regitz, M., Scherer, O. J., Eds.; Thieme: Stuttgart, Germany, 1990; p 220.

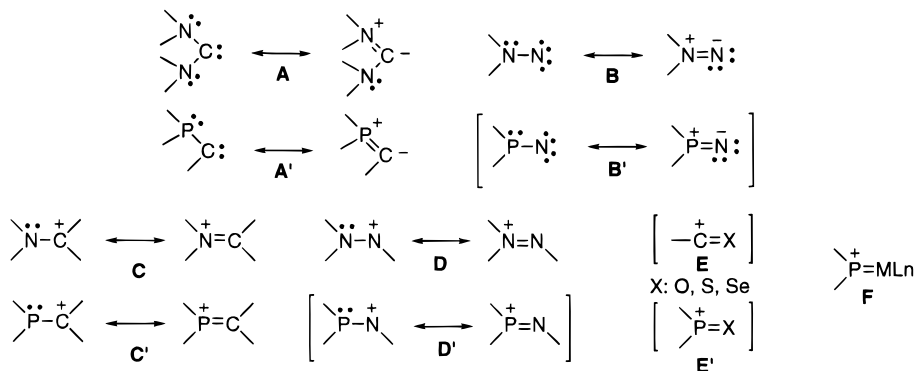

FIGURE 1. Nitrogen- and phosphorus-substituted electron-deficient species and cations.

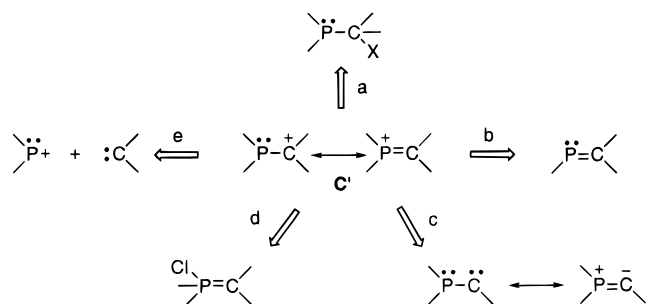
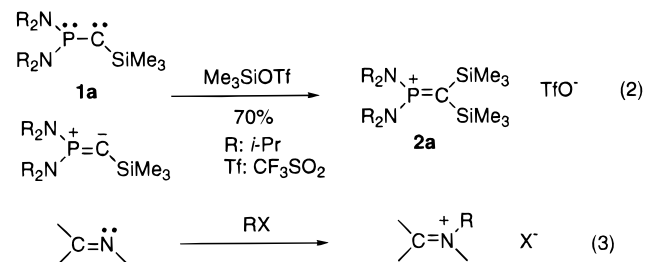
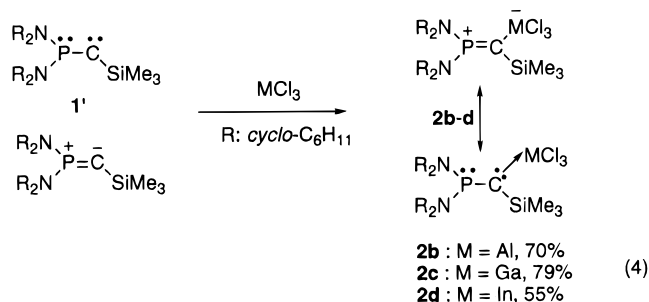

FIGURE 2. Retrosynthetic analysis of methylenephosphonium ions.

a trigonal planar phosphorus atom.³ Silylation with trimethylsilyl trifluoromethanesulfonate led to **2a** in 70% yield (eq 2). It is interesting to note that this route involving an electrophilic addition at carbon is analogous to that used for the synthesis of iminium salts from imines (eq 3), but the roles of carbon and the heteroatom are reversed.¹²



Note that replacing the silylating agent by a Lewis acid (AlCl_3 , GaCl_3 , and InCl_3), route c, allows the synthesis of zwitterionic methylenephosphonium salts **2b–d**, which can also be considered to some extent as carbene–Lewis acid complexes (eq 4).¹³



(11) Igau, A.; Grützmacher, H.; Pritzkow, H.; Baceiredo, A.; Bertrand, G. *J. Am. Chem. Soc.* **1989**, *111*, 6853.

Route d was successfully used by Grützmacher to synthesize methylene phosphonium ions **2e–g** from the corresponding *P*-chloromethylenephosphoranes **3e–g** by abstraction of chloride using AlCl_3 (eq 5).¹⁴

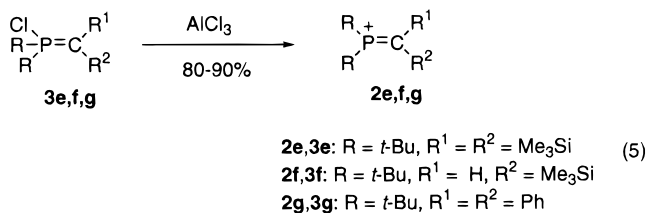

2e,3e: R = *t*-Bu, R¹ = R² = Me₃Si
2f,3f: R = *t*-Bu, R¹ = H, R² = Me₃Si
2g,3g: R = *t*-Bu, R¹ = R² = Ph

Comparison with route a highlights the comparative weakening of the P–Cl bond which is induced by an interaction between the lone pair of the ylidic carbon with the σ^* orbital of the P–Cl bond. This has been proven by an X-ray analysis of *P*-chloromethylenephosphorane **3g**.^{14b} Indeed, derivative **3g** crystallized as three different rotamers, the P–Cl bond length reaching a maximum when the torsion angle θ was close to 0°, as expected from the concept of negative hyperconjugation.¹⁵ Once again, this route is comparable to the formation of iminium salts by heterolytic cleavage of a C–X bond: the ylidic carbon lone pair acts toward the phosphorus–chlorine bond in a manner analogous to the way the nitrogen lone pair behaves toward the carbon–X bond (Figure 3).

The limitation of route d is illustrated by the reaction of chlorophosphoranes **3h,i** with GaCl_3 which affords the covalent complexes **4h,i**¹⁶ and not, contrary to previous reports,¹⁷ the methylenephosphonium salts **2h,i**. The *P*-diethylamino *C*-substituted gallium complex **4h** is stable in solution, while the *P*-diisopropylamino analogue **4i** undergoes a quantitative isomerization into heterocycle **2i'** via a ring expansion, possibly involving the methyl-

(12) The proton affinity for the parent (phosphino)(silyl)carbene ($\text{H}_2\text{-PCSiH}_3$), studied by ab initio methods, appears to be high: Dixon, D. A.; Dobbs, K. D.; Arduengo, A. J., III; Bertrand, G. *J. Am. Chem. Soc.* **1991**, *113*, 8782.

(13) Cowley, A. H.; Gabbai, F. P.; Carrano, C. J.; Mokry, L. M.; Bond, M. R.; Bertrand, G. *Angew. Chem., Int. Ed. Engl.* **1994**, *33*, 578.

(14) (a) Grützmacher, H.; Pritzkow, H. *Angew. Chem., Int. Ed. Engl.* **1991**, *30*, 709. (b) Grützmacher, H.; Pritzkow, H. *Angew. Chem., Int. Ed. Engl.* **1992**, *31*, 99.

(15) Schleyer, P. v. R.; Kos, A. J. *Tetrahedron*, **1983**, *39*, 1141. Vincent, M. A.; Schaeffer, H. F., III; Schier, A.; Schmidbauer, H. *J. Am. Chem. Soc.* **1983**, *105*, 3806. Bestmann, H. J.; Kos, A. J.; Witzgall, K.; Schleyer, P. v. R. *Chem. Ber.* **1986**, *119*, 1331. Schoeller, W. W.; Niemann, J. *J. Am. Chem. Soc.* **1986**, *108*, 22.

(16) Burford, N.; Clyburne, J. A. C.; Sereda, S. V.; Cameron, T. S.; Pincock, J. A.; Lumsden, M. *Organometallics* **1995**, *14*, 3762.

(17) Appel, R.; Schmitz, R. *Chem. Ber.* **1983**, *116*, 3521.

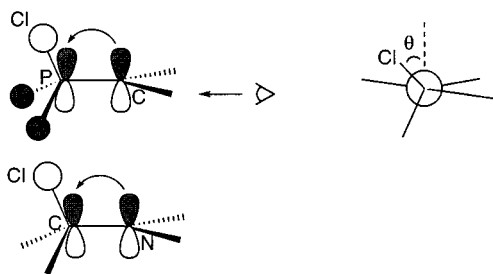
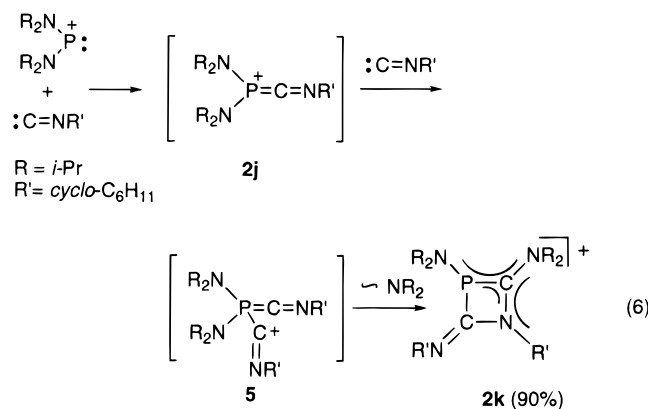

FIGURE 3. Negative hyperconjugation in phosphorus ylides and chloromethyleneamines.

enephosphonium **2i** (Figure 4). The structure of **2i'**, which can be considered to some extent as the methylene phosphonium **2'i**, will be discussed below.

Route e, the reaction between a carbene and a phosphonium salt, has been achieved using an isocyanide as the carbenoid reagent.¹⁸ However, the expected cumulenonic methylenephosphonium ions, such as **2j** could not be characterized, reacting further with a second equivalent of isocyanide, giving **5**, which subsequently underwent a ring closure followed by migration of an amino group from phosphorus to carbon. From NMR data, the authors concluded that the final product, **2k**, could be considered to some extent as a methylenephosphonium (eq 6).¹⁸



Note that a comparable approach involving an organometallic fragment isolobal to a carbene afforded phosphonium complexes, which where the first class of compounds featuring a trigonal planar phosphorus to be structurally characterized (eq 7).⁷

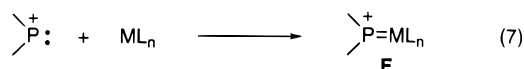

Two stable cumulenonic methylenephosphonium ions **2l,m** have been synthesized in our group using a route which does not appear in Figure 2. Addition of trifluoromethanesulfonic acid to bis(phosphino)diazomethane **6** led to the cationic diazo compound **7**, which underwent nitrogen elimination at temperatures above -20°C , affording **2l** (eq 8).^{19a} In the same way, diazo derivative **9**, obtained by addition of the bis(diisopropylamino)-

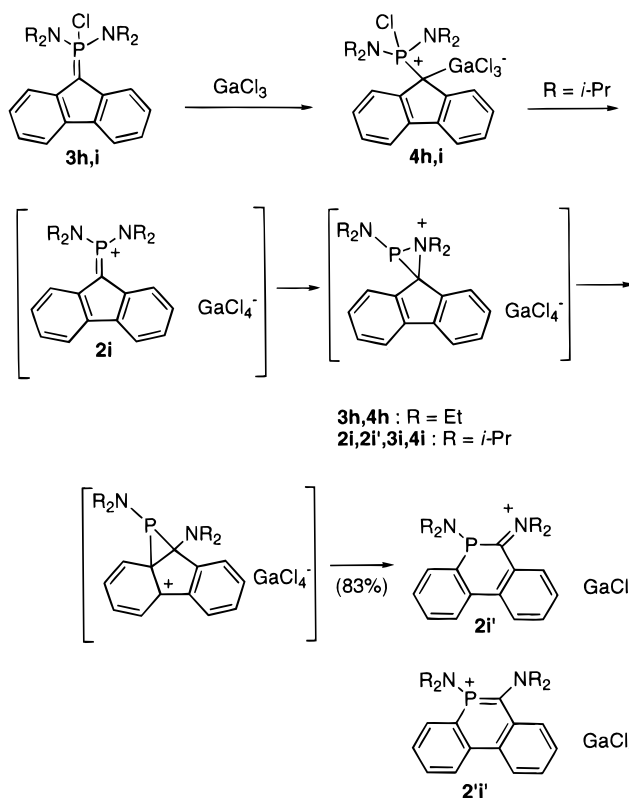
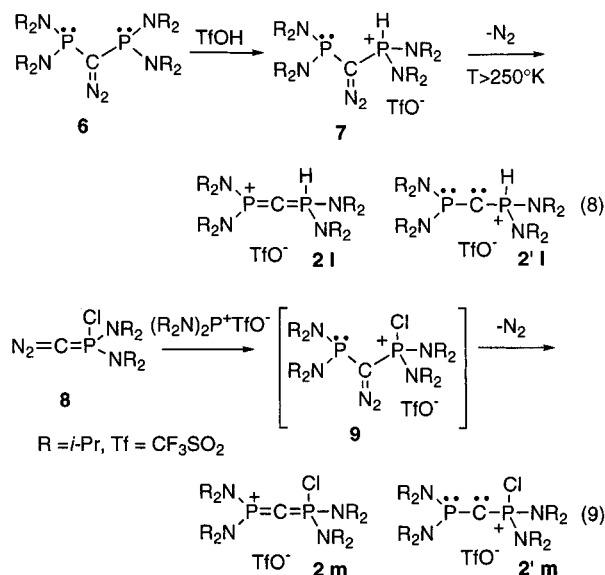

FIGURE 4. Proposed mechanism for the formation of **2i'**.

phosphonium salt to the (diazomethylene)phosphorane **8**,²⁰ gave rise to **2m** (eq 9).²¹ Since derivatives **2l,m** can also be regarded as carbenes **2'l,m** (vide infra),^{19b} **7** and **9** are nice examples of unstable diazo compounds leading to stable carbenes!



(b) Structural and Spectroscopic Data. Selected NMR and X-ray data for the known methylenephosphonium ions are summarized in Table 1, while computed data,²² including atomic charges, are given in Table 2.

(18) Roques, C.; Mazieres, M. R.; Majoral, J. P.; Sanchez, M.; Foucaud, A. *J. Org. Chem.* **1989**, *54*, 5535.

(19) (a) Soleilhavoup, M.; Baceiredo, A.; Treutler, O.; Ahlrichs, R.; Nieger, M.; Bertrand, G.; *J. Am. Chem. Soc.* **1992**, *114*, 10959. (b) For a discussion concerning the structure of the stable versions of carbenes see: Dagani, R. *Chem. Eng. News* **1991**, *69*(4), 19. Regitz, M. *Angew. Chem., Int. Ed. Engl.* **1991**, *30*, 674.

(20) Sotiropoulos, J. M.; Baceiredo, A.; Bertrand, G. *J. Am. Chem. Soc.* **1987**, *109*, 4711. Sotiropoulos, J. M.; Baceiredo, A.; Horchler, K.; Dahan, F.; Bertrand, G. *Angew. Chem., Int. Ed. Engl.* **1991**, *30*, 1154. Bourissou, D.; Bertrand, G. *C. R. Acad. Sc. Paris* **1996**, *322*, 489.

(21) Dyer, P.; Baceiredo, A.; Bertrand, G. *Inorg. Chem.* **1996**, *35*, 46.

(22) (a) Ehrig, M.; Horn, H.; Kölmel, C.; Ahlrichs, R. *J. Am. Chem. Soc.* **1991**, *113*, 3701. (b) Treutler, O.; Ahlrichs, R.; Soleilhavoup, M. *J. Am. Chem. Soc.* **1993**, *115*, 8788.

Table 1. Selected NMR and X-ray Data for Methylenephosphonium Ions

compd	NMR data			X-ray data		ref
	$\delta^{31}\text{P}$ (ppm)	$\delta^{13}\text{C}$ (ppm)	J_{PC} (Hz)	P–C (Å)	twist angle (deg)	
2a	131	76.5	87.6	1.62	60	11
2b	129					13
2c	130	84.2	83.4	1.61	34	13
2d	131					13
2e	259	178.8	8.6			14a
2f	245	149.6	45.2	1.69	11	14a
2g	183	178.1	73.6	1.68	20	14b
2i'	22	213.9	89.2	1.90		16
2l	27	98.9	157.9	1.55		19a
2m	52	103.8	153.7			21

Table 2. Computed Data^{22a} for Methylenephosphonium Ions $\text{R}_2\text{P}=\text{CR}'_2^+$ (SCF/DZP-TZP Level)

R	R'	twist angle (deg)	P–C bond length (pm)	Q_{P}^a	Q_{C}^a	ΔG^\ddagger ^b (kcal/mol)
H	H	0	162.3	0.7	-0.2	
Me	Me	0	164.2	0.9	-0.2	33,8
H	SiH ₃	0	161.9	0.7	-0.7	
NH ₂	H	14.5	159.8	1.3	-0.5	
NH ₂	SiH ₃	15.0	159.3	1.4	-1.0	20
NMe ₂	SiH ₃	23.5	160.2	1.3	-1.0	
N(Pr) ₂	SiH ₃	31.5	161.1	1.3	-0.9	
N(Pr) ₂	SiMe ₃	38.1	161.6	1.3	-0.9	

^a Atomic charges according to population analysis based on occupation number. ^b Energy of the rotation barrier around the P=C bond.

The ionic structure of methylenephosphonium ions is suggested by their low solubility in nonpolar solvents and is confirmed by the deshielding of both the ³¹P NMR signal and the ¹³C NMR signals of the methylene carbon atom compared to those of the corresponding *P*-chloromethylenephosphoranes. For example, **2a**: $\delta^{31}\text{P}$, +131 ppm; $\delta^{13}\text{C}$, 76 ppm. **3a**: $\delta^{31}\text{P}$, +72 ppm; $\delta^{13}\text{C}$, 12 ppm. **2e**: $\delta^{31}\text{P}$, +259 ppm; $\delta^{13}\text{C}$, 179 ppm. **3e**: $\delta^{31}\text{P}$, +106 ppm; $\delta^{13}\text{C}$, 28 ppm. In the solid state, no interactions were observed with the counteranion. Both the phosphorus and carbon atoms of all of the structurally characterized noncumulenic methylenephosphonium ions **2a,c,f,e** adopt a trigonal planar geometry, which means that there is donation of the phosphorus lone pair into the vacant orbital at carbon. The phosphorus–carbon bond length is short as expected for compounds which are isostructural with olefins; however, the double bond is dramatically twisted, up to 60° in the case of **2a** which is larger than in the “most crowded olefin” reported by Sakurai (50.2°).²³

Theoretical studies, by Malrieu and Trinquier²⁴ and Carter and Goddard²⁵ have justified the planarity at phosphorus and carbon, while Ahlrichs has rationalized the combination of the large twist angle and the short bond length.²² According to the latter study (Table 2) two main effects determine the geometry around the double bond:²⁶ Coulombic attraction influences the P–C bond length and steric hindrance imposes the twist angle of the

Scheme 1

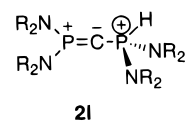

double bond. These conclusions clearly explain the differences observed when comparing the experimental data for compounds **2a–d** on one hand and **2e–g** on the other: lower field for both ³¹P and ¹³C chemical shifts, lengthening of the P–C bond, and a decrease of the twist angle θ for **2e–g**, compared to **2a–d**. For example, in **2a**, the electronegative amino substituents at phosphorus and electropositive silyl groups at carbon enhance the polarity of the P–C bond ($Q_{\text{P}} = +1.3$ and $Q_{\text{C}} = -0.9$), which explains the comparatively short bond (1.62 Å), while the bulk of all these substituents is the cause of the large twist angle (60°). When the substituents are less polarizing and less bulky, as in **2f**, the P–C bond is longer (1.69 Å) and the twist angle smaller (11°).

The value of the barrier to rotation around the P–C bond is also sensitive to electronic factors. Grützmaier synthesized analogues of **2g**, with two different aryl groups at carbon.²⁷ According to ¹H NMR, no equilibration of the inequivalent *tert*-butyl groups was observed up to 60 °C, which sets a lower limit for the barrier to rotation of $\Delta G^\ddagger = 83$ kJ/mol; in contrast, the same author found that in compound **2f** the ¹H NMR signals of the *tert*-butyl groups were equivalent even at temperatures as low as -90 °C, implying a very low energy barrier.^{14a} Similar differences were observed by calculation (Table 2).^{6,22}

It has to be mentioned that for the cumulenic methylenephosphonium salt **2l**, the σ^3 -phosphorus atom is planar, the σ^3 (P–C) and the σ^4 (P–C) bonds are extremely short (1.557 and 1.698 Å, respectively) and that the PCP skeleton is almost linear (166°).¹⁹ According to calculation,^{22b} both phosphorus atoms are strongly positive (σ^3 -P, +1.1; σ^4 -P, +1.1), while the carbon atom bears a negative charge (-0.9). Therefore, from a structural point of view, **2l** can be regarded not as the carbene **2l'**^{19b} but is best described as depicted in Scheme 1.

Together these observations show that although high barriers to inversion in R_2P groups hampers π -donation, the lone pair at phosphorus stabilizes carbocations to a considerable extent. It is important to note that in all the calculations the phosphorus atom bears the positive charge and one could say, referring to a methylenephosphonium as a phosphino carbocation, that the positive charge has been transferred from carbon to phosphorus.

The superiority of nitrogen compared to phosphorus,⁶ in delocalizing the lone pair into the carbocation empty orbital is well illustrated by the results of single-crystal X-ray analyses of compounds **2i'**¹⁶ and **2n'**²⁸ (Scheme 2). Indeed, in both compounds, the nitrogen atom bound to carbon is planar, while the phosphorus atom is pyramidal; the P–C bond is long, while the CN bond is short. This is especially striking in the case of **2i'**, since the methyl-

(23) Sakurai, H.; Ebata, K.; Kabuto, C.; Nakadaira, Y. *Chem. Lett.* **1987**, 301.

(24) Trinquier, G.; Malrieu, J. P. *J. Am. Chem. Soc.* **1987**, *109*, 5303. Malrieu, J. P.; Trinquier, G. *Ibid.* **1989**, *111*, 5916. Trinquier, G.; Malrieu, J. P. In *The chemistry of functional groups, Suppl. A: The chemistry of double-bonded functional groups, Vol. 2, Part 1*; Patai, S., Ed.; Wiley: Chichester, U.K., 1989; p 1.

(25) Carter, E. A.; Goddard, W. A., III. *J. Phys. Chem.* **1986**, *90*, 998.

(26) For a review on main group element analogues of olefins, see: Driess, M.; Grützmaier, H. *Angew. Chem., Int. Ed. Engl.* **1996**, *35*, 829.

(27) Heim, U.; Pritzkow, H.; Schönberg, H.; Grützmaier, H. *J. Chem. Soc., Chem. Commun.* **1993**, 673.

(28) Leriche, Y.; Goumri, S.; Baceiredo, A.; Bertrand, G. Unpublished results.

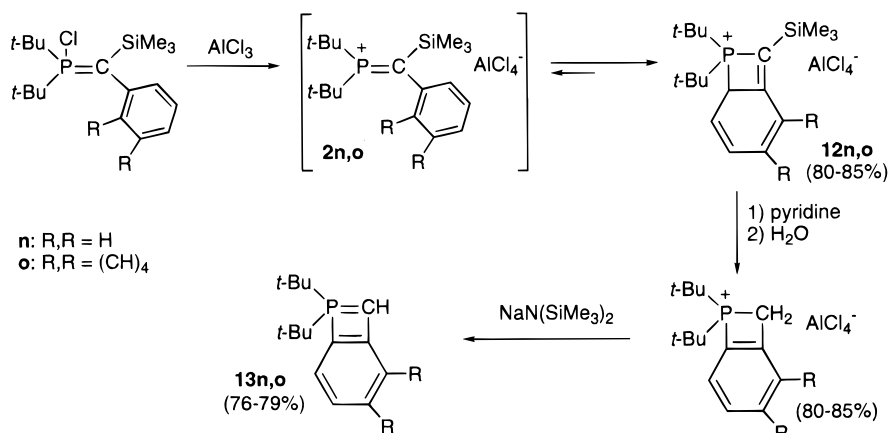
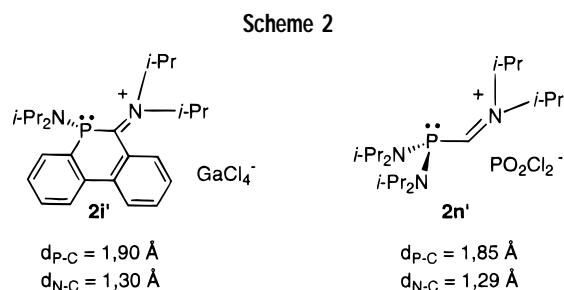
FIGURE 5. Synthesis of the first λ^5 -phosphetes.

enephosphonium form could be regarded as a phosphonium salt **2i'**, analogous to a pyridinium salt, and thus could be stabilized by aromaticity (see eq 1).

(c) Reactivity. As stable methylenephosphonium ions are difficult to synthesize, the reactivity of these species has been poorly studied; however, interesting reactions have been observed with their transient congeners. Rather than to present the results according to the stability of methylenephosphonium ions, we have preferred to emphasize the effects of the substituents on their chemical behavior.

Due to the localization of the positive charge at phosphorus, all types of methylenephosphonium ions react toward nucleophilic anions (F^- , Cl^- , MeO^-) affording the corresponding phosphorus ylides.

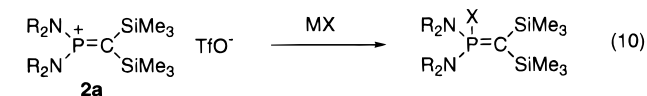

R: *i*-Pr; MX: LiCl, CsF, NaOMe

As a result, the cumulenyl methylenephosphonium salt **2i** has been used as a precursor for the synthesis of the first carbodiphosphorane with P–H bonds **10**.²⁹ This compound, which was characterized by NMR spectroscopy, rearranged in solution first into the C-phosphino phosphorus ylide and then into the corresponding diphosphine. According to calculations,^{22b} **10** is 120 and 260 kJ mol⁻¹ higher in energy than the ylide and the phosphine, respectively, which makes the characterization of the carbodiphosphorane **10** rather surprising (eq 11). Also noteworthy is the reaction of **2f** with an excess of $AlCl_3$, which afforded the adduct **11**, formally resulting from the

addition of Cl^- at phosphorus and Al_2Cl_6 to the negatively charged carbon center (eq 12).³⁰

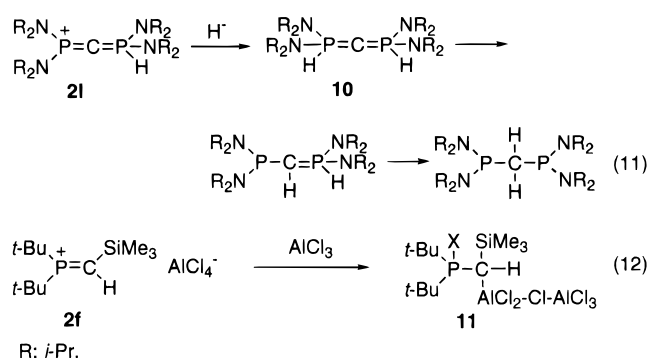

The presence of a highly electrophilic center, enhanced by the polarizing effect of two *tert*-butyl groups at phosphorus and a silyl group at carbon, allows transient methylenephosphonium ions **2n,o** (Figure 5) to be in equilibrium via an intramolecular electrocyclic ring closure, with dihydrophosphetium salts **12n,o**.³¹ The authors assume that the change in coordination geometry at the phosphorus center (from trigonal planar in **2n,o** to tetrahedral in **12n,o**) compensates for the loss of conjugation of the aryl ring as well as for the ring strain caused by the formation of the four-membered ring. Further treatment of compounds **12n,o** with pyridine followed by hydrolysis of the C–Si bond and deprotonation with a strong base led to the first isolated λ^5 phosphetes **13n,o** (Figure 5).^{32,33}

Whereas *P*-amino-substituted methylenephosphonium ions are reluctant to react with unsaturated compounds, *P*-*tert*-butyl analogues undergo ene and/or Diels–Alder reactions, depending on the carbon substituents. With the strongly polarized cation **2e**, the addition of dimethylbutadiene only gave rise to the ene adduct **14e**, while using **2f**, the Diels–Alder adduct **15f** was obtained.^{14a} With transient **2n**, which is located electronically between **2e,f**, both types of adducts **14n** and **15n** were isolated.³¹ Note

(30) Thomaier, J.; Alcaraz, G.; Grützmacher, H.; Hillebrecht, H.; Marchand, C.; Heim, U. *J. Organomet. Chem.* **1997**, in press.

(31) Heim, U.; Pritzkow, H.; Fleischer, U.; Grützmacher, H. *Angew. Chem., Int. Ed. Engl.* **1993**, *32*, 1359.

(32) Heim, U.; Pritzkow, H.; Fleischer, U.; Grützmacher, H.; Sanchez, M.; Réau, R.; Bertrand, G. *Chem. Eur. J.* **1996**, *2*, 68.

(33) For reviews on ylidic four-membered rings with four π -electrons, see: Weber, L. *Angew. Chem., Int. Ed. Engl.* **1996**, *35*, 2618. Bertrand, G. *Angew. Chem., Int. Ed. Engl.*, in press.

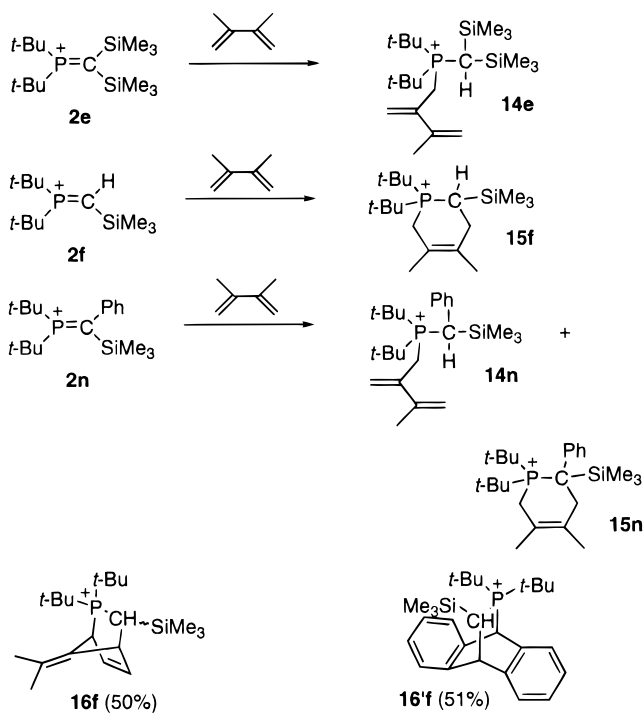

FIGURE 6. Ene and Diels–Alder reactions involving methylenephosphonium salts.

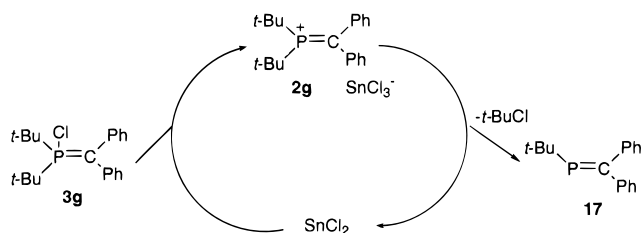

FIGURE 7. Catalytic formation of phosphalkene 17.

that **2f** also reacts with dimethylfulvene and anthracene, affording the Diels–Alder adducts **16f** and **16'f**, respectively (Figure 6).³⁰

Methylenephosphonium **2g-SnCl₃⁻** appeared to be much less stable than **2g-AlCl₄⁻**, stressing the role of the anion; it decomposed according to a first-order rate law to phosphalkene **17**. The overall transformation of **3g** to **17** represents the first catalytic synthesis of methylenephosphanes and is of preparative value, since the starting material **3g** is easily available (Figure 7).^{14b}

The zwitterionic methylenephosphonium ions **2b–d** synthesized using group 13 trihalides are stable. However using group 13 trialkyls, the corresponding derivatives **2p–s** appeared to be unstable (although **2p** was characterized by low-temperature NMR spectroscopy) and underwent fragmentation into phosphalkene **18p** or rearranged into ylides **19q–s**.^{13,34} Most probably, in all cases, the first step is a 1,2-migration from the four-coordinated group 13 atom to the carbon, followed by either 1,2-elimination of diethyl(dicyclohexylamino)borane giving **18p** or isomerization into phosphorus ylides **19q–s** (methylenephosphane–phosphorus ylide conversions are well exemplified³⁵) (eq 13). Derivative **19r** is of special

(34) Horchler v. Locquenghien, K.; Baceiredo, A.; Boese, R.; Bertrand, G. *J. Am. Chem. Soc.* **1991**, *113*, 5062. Alcaraz, G.; Reed, R.; Baceiredo, A.; Bertrand, G. *J. Chem. Soc., Chem. Commun.* **1993**, 1354.

(35) Appel, R.; Huppertz, M.; Westerhaus, A. *Chem. Ber.* **1983**, *116*, 114.

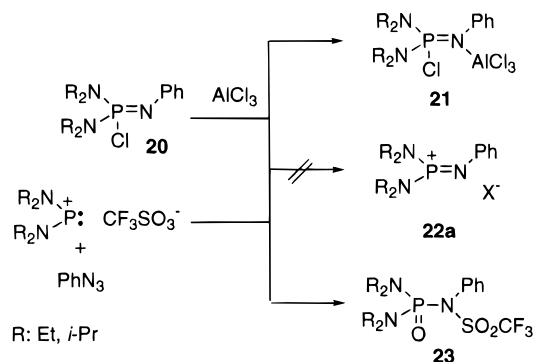
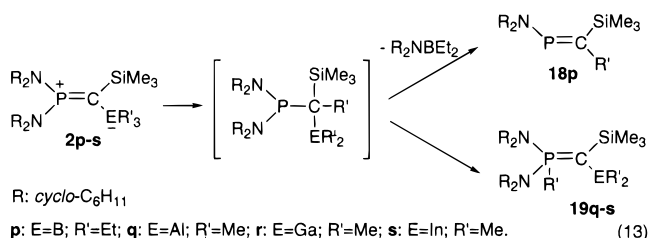

FIGURE 8. Attempted syntheses of iminophosphonium salts.

interest since it is the first well-characterized *C*-gallyl-substituted phosphorus ylide; it features a short gallium–carbon bond indicating a slight multiple bond character.



B. Iminophosphonium Ions. In 1982 Sanchez et al.³⁶ recognized that the *P*-chlorophosphazene unit **20** and the Staudinger reaction between a phosphonium salt and an azide were potential sources for iminophosphonium salts **22a**. However, more recent studies by Chernega et al.³⁷ and Burford³⁸ revealed alternative structural arrangements for these species, which are either covalent aluminum trichloride Lewis-base complexes **21** or adducts from the rearrangement of iminophosphoniums with the triflate counteranion **23** (Figure 8).

The only stable iminophosphonium ion **22b** reported so far results from a Curtius-type rearrangement involving the tris(dimethylamino)azidophosphonium hexafluorophosphate (**24**).³⁹ Owing to the presence of an amino group at nitrogen, derivative **22b** can also be regarded as a phosphine substituted by an N=NMe₂⁺ group or a phosphinoaminonitrenium, which is related to the allylic systems calculated by Schoeller.⁴⁰ The assignment of the structure of **22b** was based on NMR spectroscopy (δ ³¹P, +77 ppm) and on the formation of the hydrolysis product **25**, which probably results from initial nucleophilic attack at the positive phosphorus atom by the hydroxy group of water (eq 14).

Since we have shown that stable zwitterionic methylenephosphonium salts of types **2b–d** were available starting from the phosphinocarbene **1**, we attempted the

(36) Marre, M. R.; Sanchez, M.; Wolf, R. *Phosphorus Sulfur* **1982**, *13*, 327; **1983**, *14*, 453. Marre, M. R.; Sanchez, M.; Wolf, R. *J. Chem. Soc., Chem. Commun.* **1984**, 566.

(37) Chernega, A. N.; Antipin, M. Yu.; Struchkov, Yu. T.; Boldeskul, I. E.; Marchenko, A. P.; Pinchuk, A. M. *Zh. Strukt. Khim.* **1987**, *28*, 135. Marchenko, A. P.; Miroshnichenko, V. V.; Kovenya, V. A.; Pinchuk, A. M.; Chernega, A. N.; Antipin, M. Yu.; Struchkov, Yu. T. *Zh. Obshch. Khim.* **1988**, *58*, 1758.

(38) Burford, N.; Spence, R. E. v. H.; Richardson, J. F. *J. Chem. Soc., Dalton Trans.* **1991**, 1615.

(39) Mulliez, M.; Majoral, J. P.; Bertrand, G. *J. Chem. Soc., Chem. Commun.* **1984**, 284.

(40) Schoeller, W. W.; Busch, T. *Chem. Ber.* **1990**, *123*, 971.

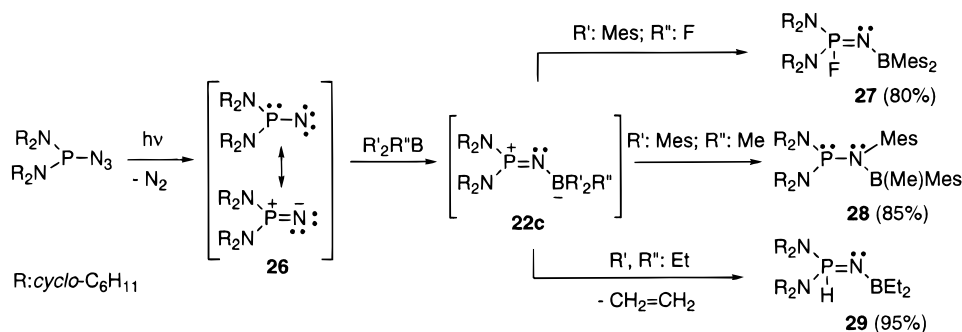
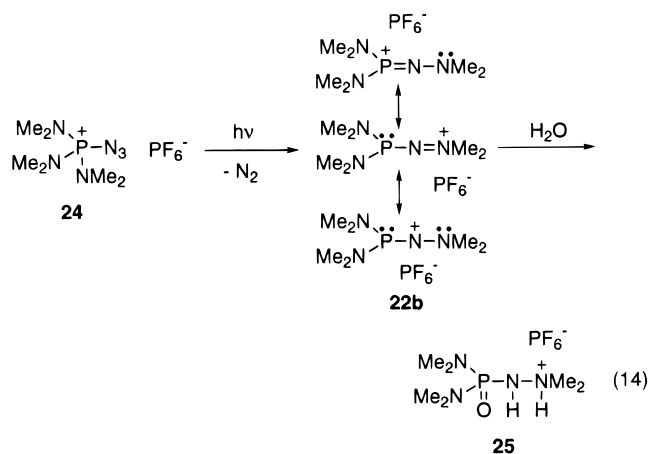

FIGURE 9. Reactivity of transient phosphininonitrene 26 with various boranes.



synthesis of the related iminophosphonium salts **22c** by reacting transient phosphininonitrene **26**⁴ with different boranes. None of the desired adducts **22c** were stable, and depending on the boron substituents, they rearranged via different processes.⁴¹ With dimesitylfluoroborane, the *P*-fluoro-*N*-(borylimino)phosphorane **27** formally resulting from a 1,3-migration of fluorine from boron to phosphorus, was isolated in 80% yield. With dimesitylmethylborane, a 1,2-migration of a mesityl group from boron to nitrogen, led to the *N*-phosphino-*N*-boryl-*N*-mesitylamine **28** (85% yield). These two rearrangements are closely related to those observed with boron-carbene adducts **2p-s**.^{13,34} Since alkyl groups in borates have a poor migrating ability,⁴² the bis(dicyclohexylamino)azidophosphine was irradiated in the presence of triethylborane. Surprisingly, a retro-ene reaction took place, leading to *P*-hydrido-*N*-(borylimino)phosphorane **29** in near quantitative yield, along with ethylene (Figure 9). These results, as a whole, demonstrate the difficulty in isolating iminophosphonium salts.

C. Oxo-, Thioxo-, and Selenoxophosphonium Ions.

For a long time, the transient formation of oxophosphonium ions (or phosphacylium) via nucleophilic displacement at tetracoordinated phosphorus has been discussed.⁴³ However, in the 1980s, this hypothesis was ruled out,⁴⁴ and in fact, so far, no oxophosphonium ions have been reported in the literature.

One example of a thioxophosphonium ion was described by Maier and Wartenberg in the 1960s:⁴⁵ it resulted from the reaction of AlCl_3 with $\text{Cl}_3\text{P}=\text{S}$, but recently, authors agree on the lack of characterization data.⁴⁶ Burford intended to form thioxo- and selenoxophosphonium ions, also using chlorine abstraction, but starting rather from the amino-substituted thioxo- and selenoxophosphines.⁴⁶ In solution, typical Lewis acid-base complexes **30a-c** have been observed in the case of sulfur (eq 15). In the solid state, the isopropyl derivative **30c** (82% yield) maintains its covalent structure, but interestingly, the methyl and ethyl derivatives give rise to novel dimeric heterocyclic diphosphonium systems **31a** and **b** in 77 and 86% yield, respectively (eq 16). In solution and in the presence of aluminum trichloride, the diaminoselenoxophosphinic chlorides showed no evidence for the formation of adducts of type **30**; however, once again, the heterocyclic diphosphonium salts **32a,b** (50 and 95% yield) have been isolated in the solid state. The dicationic heterocycles **31** and **32** can be regarded as dimers of the desired thioxo- and selenoxophosphonium ions, but no evidence for the intermediacy of these species has been found. In contrast, the formation of thioxophosphonium **34a** has been postulated by Burford et al. to explain the formation of heterocycle **35** in the reaction of bis[*N*-(trimethylsilyl)amino]chlorothioxophosphorane (**33**) with Lewis acids.^{46c,d} They tentatively assigned a ³¹P NMR signal at +177 ppm to the tricoordinate phosphorus species **34a**, but this assumption is highly speculative (eq 17).

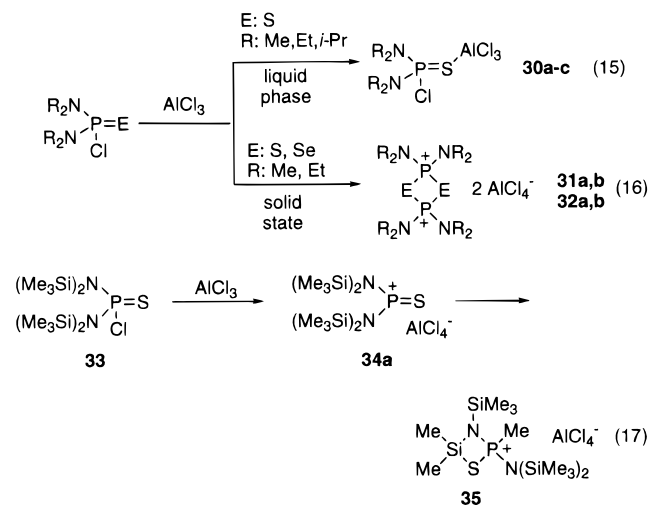

(41) Alcaraz, G.; Baceiredo, A.; Dahan, F.; Bertrand, G. *J. Am. Chem. Soc.* **1994**, *116*, 1225.

(42) Pelter, A.; Hutchings, M. G.; Smith, K.; Williams, D. J. *J. Chem. Soc., Perkin Trans. 1* **1975**, 145 and references therein.

(43) Haake, P.; Ossip, P. S. *J. Am. Chem. Soc.* **1971**, *93*, 6919; **1971**, *93*, 6924. Rahil, J.; Haake, P. *J. Org. Chem.* **1981**, *46*, 3048.

(44) Michalski, J.; Radziejewski, Cz.; Skrypczynski, Z.; Dabkowski, W. *J. Am. Chem. Soc.* **1980**, *102*, 7974.

30a: R=Me; **30b:** R=Et; **30c:** R = *i*-Pr

31a: E=S, R=Me, **31b:** E=S, R=Et

32a: E=Se, R=Me, **32b:** E=Se, R=Et

The synthesis of the zwitterionic thioxophosphonium ion **34b** has been attempted using a simple one-atom oxidative addition of sulfur to the phosphonium ion **36**.^{46c} In fact, once again heterocycle **37**, the dimer of the desired tricoordinate phosphorus cation **34b**, has been obtained in 90% yield. Contrary to the analogous heterocycles **31** and **32**, derivative **37** appeared to be stable both in solution and in the solid state (eq 18).

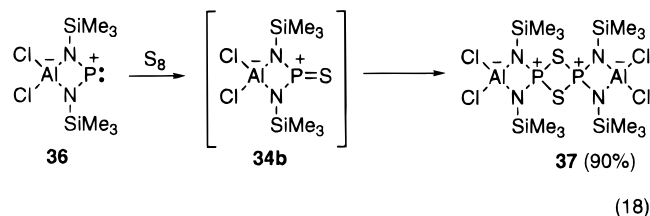

The only example of a well-characterized selenoxophosphonium ion **39** (although no X-ray data are available) has been prepared by Schmidpeter et al. also using a one-atom oxidative addition reaction.⁴⁷ In contrast to other phosphonium ions,⁴⁸ the central phosphorus atom of the starting material **38** is not only a weaker acceptor but also more nucleophilic, which allowed a base-catalyzed reaction with gray selenium. The resulting bis-(ylide)-substituted selenoxophosphonium chloride **39** was isolated in 53% yield as yellow crystals. The ionic character of **39** was proved by NMR spectroscopy, the chemical shifts being independent of the anion. The stability of this compound is due to the strong π -donor ability of the ylides as shown by the resonance structure **39'**, which also explains how the counteranion can be as nucleophilic as chloride or bromide (eq 19).

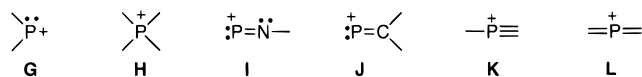
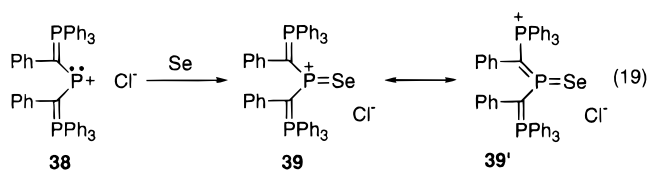

FIGURE 10. Phosphorus cations.



Conclusion

The existence of stable trigonal planar phosphorus cations of type $[R_2P=X]^+$ has been clearly demonstrated as far as X is a methylene group. These species which are isoelectronic and isovalent with olefins feature a short PC bond, mostly due to Coulombic attraction between a positively charged phosphorus and a negatively charged carbon, and depending on the steric hindrance of the substituents a large twist angle, up to 60° . A few examples of Diels–Alder and ene reactions have been reported, but the reactivity of these ions seems to be governed by the presence of a strongly electrophilic phosphorus center.

Whereas Schmidpeter has prepared a stable selenoxophosphonium derivative, he has never mentioned the corresponding thioxophosphonium ions. The search for phosphacilium ions continues, and some experimental results and theoretical studies show that this goal will be hard to reach. Burford has complexed phosphine oxides with Lewis acids and obtained linear adducts,^{49a} while with phosphine sulfides and selenides, bent adducts were observed.^{49b} This difference is well rationalized in Gilheany's review concerning the bonding in phosphorus compounds.⁵⁰ In fact, the polarization of the $P=X$ bond increases when X lies higher up among the group 16 elements and hence the electron density is more concentrated on X, phosphorus bearing an increasing positive charge. Therefore, the corresponding chalcogenophosphonium ion will have a progressively more electrophilic phosphorus center and one can guess that very peculiar substituents will be necessary, if one wants to isolate these species.

Up to the beginning of the 1970s, when Fleming et al.⁵¹ and Maryanoff and Hutchins^{51b} independently reported the first stable phosphonium cations **G**, phosphonium salts **H** were the only known phosphorus cations. More recently, Niecke et al. isolated monocoordinated phosphorus cations of types **I**⁵² and **J**.⁵³ Other types of cations featuring a phosphorus atom in various coordination states, such as **K** and **L**, will certainly be found in the near future, and this will open new exciting chapters in phosphorus chemistry (Figure 10).

AR970061A

- (45) Wartenberg, E. W.; Goubeau, J. *Z. Anorg. Allg. Chem.* **1964**, *329*, 269; Maier, L. *Ibid.* **1966**, *343*, 29.
- (46) (a) Burford, N.; Spence, R. E. v. H.; Rogers, R. D. *J. Am. Chem. Soc.* **1989**, *111*, 5006. (b) Burford, N.; Spence, R. E. v. H.; Rogers, R. D. *J. Chem. Soc., Dalton Trans.* **1990**, 3611. (c) Burford, N.; Spence, R. E. v. H.; Whalen, J. M.; Rogers, R. D. *Organometallics* **1990**, *9*, 2854. (d) Burford, N.; Mason, S.; Spence, R. E. v. H.; Whalen, J. M.; Richardson, J.; Rogers, R. D. *Ibid.* **1992**, *11*, 2241. (e) Burford, N.; Losier, P.; Bakshi, P. K.; Cameron, T. S. *Inorg. Chem.* **1994**, *33*, 5613.
- (47) Schmidpeter, A.; Jochem, G.; Karaghiosoff, K.; Robl, C. *Angew. Chem., Int. Ed. Engl.* **1992**, *31*, 1350. Jochem, G.; Karaghiosoff, K.; Plank, S.; Dick, S.; Schmidpeter, A. *Chem. Ber.* **1995**, *128*, 1207.
- (48) Sanchez, M.; Mazières, M. R.; Lamandé, L.; Wolf, R. In *Multiple Bonds and Low Coordination in Phosphorus Chemistry*; Regitz, M., Scherer, O. J., Eds.; Thieme: Stuttgart, Germany, 1990; p 129.
- (49) (a) Burford, N.; Royan, B. W.; Spence, R. E. v. H.; Cameron, T. S.; Lynden, A.; Rogers, R. D. *J. Chem. Soc., Dalton Trans.* **1990**, 1521. (b) Burford, N.; Royan, B. W.; Spence, R. E. v. H. *Ibid.* **1990**, 2111.
- (50) Gilheany, D. G. *Chem. Rev.* **1994**, *94*, 1339.
- (51) (a) Fleming, S.; Lupton, M. K.; Jekot, K. *Inorg. Chem.* **1972**, *11*, 2534. (b) Maryanoff, B. E.; Hutchins, R. O. *J. Org. Chem.* **1972**, *37*, 3475.
- (52) Niecke, E.; Nieger, M.; Reichert, F. *Angew. Chem., Int. Ed. Engl.* **1988**, *27*, 1713. Niecke, E.; Nieger, M.; Reichert, F.; Schoeller, W. W. *Ibid.* **1988**, *27*, 1715. Niecke, E.; Detsch, R.; Nieger, M.; Reichert, F.; Schoeller, W. W. *Bull. Soc. Chim. Fr.* **1993**, *130*, 25.
- (53) David, G.; Niecke, E.; Nieger, M.; Radseck, J.; Schoeller, W. W. *J. Am. Chem. Soc.* **1994**, *116*, 2191.